



**ROYTEC**  
Global Separation Solutions

Johannesburg | Perth | Toronto | Yantai | Santiago

---

## ROYTEC TOWER FILTER PRESSES™

---



**MARKET LEADERS IN  
LIQUID / SOLID SEPARATION**

# ROYTEC TOWER FILTER PRESSES

**ROYTEC GLOBAL is an International Company specializing in Liquid / Solid and mineral Separation technologies for the Mining and Industrial sectors.**

Roytec is privately owned by Directors and Managers. We are passionate about excellence in our services and we pride ourselves in delivery to our promises. Our equipment is fully supported by Roytec Specialists based in Johannesburg, South Africa; Perth, Australia; Toronto, Canada; Yantai, China and Santiago, Chile.



## TONCIN TOWER PRESS

Roytec have a manufacturing agreement with Nuclear Industry YanTai Tonicin Group Co.,Ltd. who have the capability to deliver 600 Tower Filter Presses per year. Tonicin is a high-tech enterprise specialising in solid / liquid separation technology. Our agreement with Tonicin allows for the major filter components (Frame, Plates, etc.) to be manufactured in China, with the mechanical equipment (Gearboxes, pumps, electrics, instruments, etc.) being Western brands fitted by Roytec. The resultant filter is a combination of competitive manufacturing cost, with locally available mechanical components.

## ASIA'S FILTRATION TECHNOLOGY LEADER

- 2000 Employees & 1,5Billion RMB sales
- ISO 9000, 14000 & 24000 / CE certified
- Largest Tower Press manufacturer in Asia
- 250 units over last 10 years up to 168m<sup>2</sup>
- Cost Competitive (Main Components manufactured in China)
- Mechanical Components all international brands – Rexroth/WEG/SEW/SKF/Siemens etc.
- Global Project Management (Local POs, project specifications, QA/QC, mechanical components available locally project managed by Roytec Global)
- Globally serviced & guaranteed by Roytec Global – spares stocked in Johannesburg, Perth & Yantai

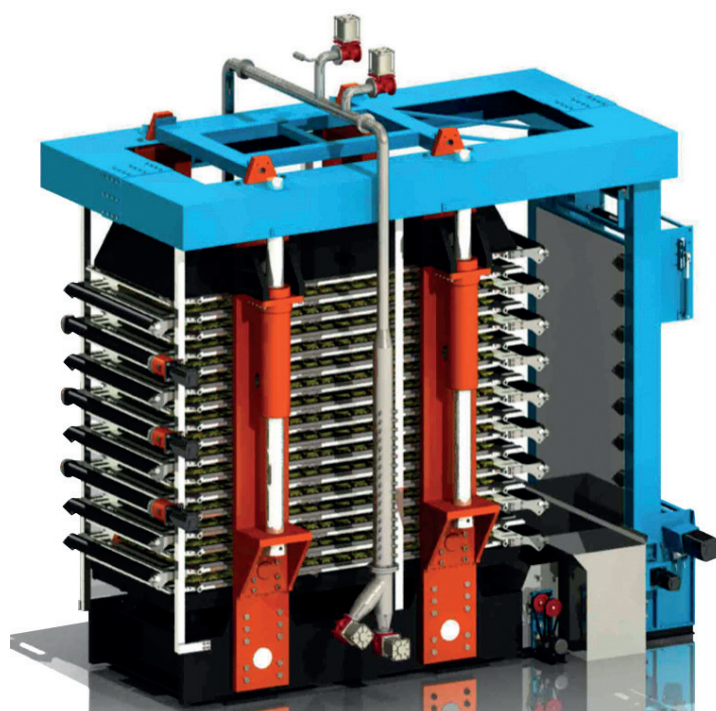

## COST OF TOWER PRESSES

### Traditionally the capital cost of Tower Presses has been relatively high

- In truth, there is nothing to justify the high Capital price levels that have been paid Globally for this technology.
- The perceived monopoly in the technology is fast evaporating, with Toncin already dominant in the East.

### Traditionally the cost of maintenance has been high

- Historically the price of spares and service has been a concern to clients.
- These inflated costs have pushed the total cost of ownership of European Tower Presses higher than almost all other process equipment.

### Roytec-Toncin Solution

- Toncin has made clear inroads in reducing the total cost of ownership by retrofitting competitor's presses with reasonably priced spare parts.
- Total cost of ownership can reduce by approximately 40% when compared to the competitor.
- Toncin have a strong business in re-building the competitors Tower Presses, including;
  - Filtration Plates and Drainage Grids
  - Diaphragms and Seals

## PRINCIPLES OF OPERATION

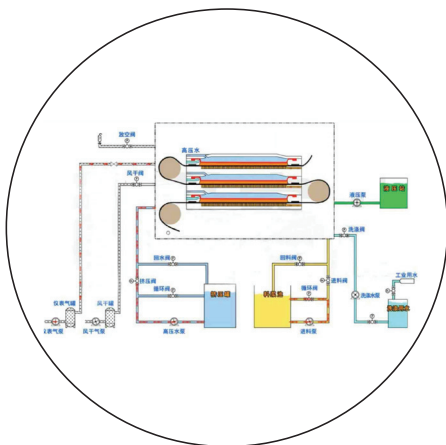

## TONCIN TOWER PRESS BENEFITS & FEATURES

### Summary of Features

A Vertical Tower Filter Press filter is a high-efficiency, low energy consumption, highly automated solid-liquid separation filter. The pressure provided by the feed pump, gravity and air/water pressure on the diaphragms, is used to achieve efficient solid-liquid separation.

### Features:

- The filter plates are stacked within the plate guide system.
- Filtration, membrane squeeze, air-blow drying, and discharging of the cakes is done automatically.
- The filter cloth is automatically washed each cycle, maintaining good filtration rates and maximising the life of the filter cloth.
- Feed pressures of up to 16 bar can be used to increase the solid/liquid separation efficiency and/or to meet low cake moisture requirements
- The use of a PLC, with touch screen and automated control valves, ensure easy and flexible filter operation, reducing production costs and labour requirements.
- Compact structure and a small foot-print are features of the design.

## TONCIN TOWER PRESS APPLICATIONS

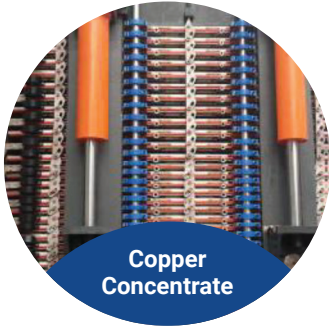

**Copper  
Concentrate**



**Iron Ore  
Fines**



**Platinum  
Concentrate**



**PGM  
Concentrate**

## SIZES WE SUPPLIED



**4 x 120m<sup>2</sup>  
Tower Presses  
- Fe Fines**

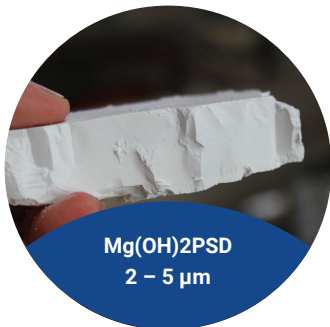

**Mg(OH)<sub>2</sub>PSD  
2 - 5 μm**



**Jiangxi Lithium  
7 x 168m<sup>2</sup>  
Tower Presses**



**10 x 120m<sup>2</sup>  
Tower Presses  
Al(OH)<sub>3</sub>  
(Fire Retardants)**

## TONCIN TOWER PRESSES PRODUCT RANGE

### PLATE SIZES

1.6m<sup>2</sup> 1 - 27m<sup>2</sup> operating area  
2.5m<sup>2</sup> 15 - 50m<sup>2</sup> operating area  
6.0m<sup>2</sup> 60 - 168m<sup>2</sup> operating area

**CAKE THICKNESS** - 30, 45 or 60mm

**OPERATING PRESSURE** - Up to 16 Bar

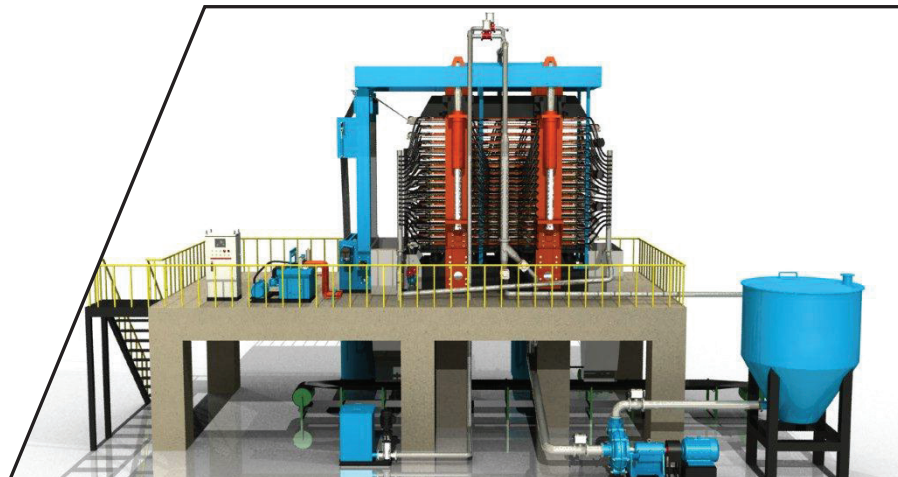

## ANCILLARIES

### INCLUDED

- Hydraulic cylinders and Power-pack
- Control system
- Filter cloth
- Tracking Roller
- Diaphragm squeeze station
- Discharge chutes to bottom of filter level
- Commissioning spare-parts

### EXCLUDED (OPTIONAL)

- Air-blow dry compressor and accumulator
- Cloth washing pump
- Cake washing pump
- 2 years spare-parts
- Strategic spares

## TONCIN TOWER PRESS AFTER-MARKET SERVICE & PARTS

Full range of OEM compatible and interchangeable spare parts.

- Complete Plate pack replacement of individual components.
- Stainless Steel Plate, Stainless Steel Frame, Drainage Grids sets, Seals Sets, VATS, Rubber Diaphragms, Filter Cloths, Guide Rollers, Roller Support Brackets, Scrapers Sets and mounting hardware.

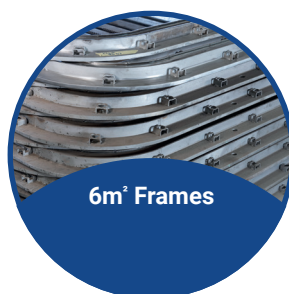
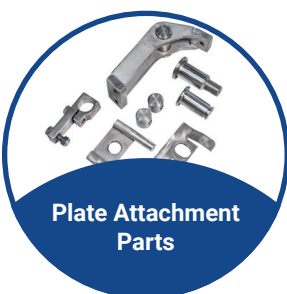
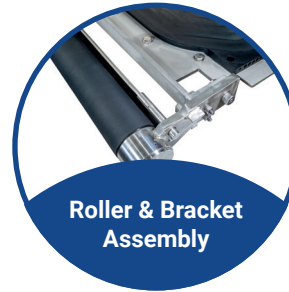
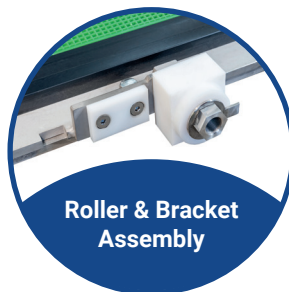
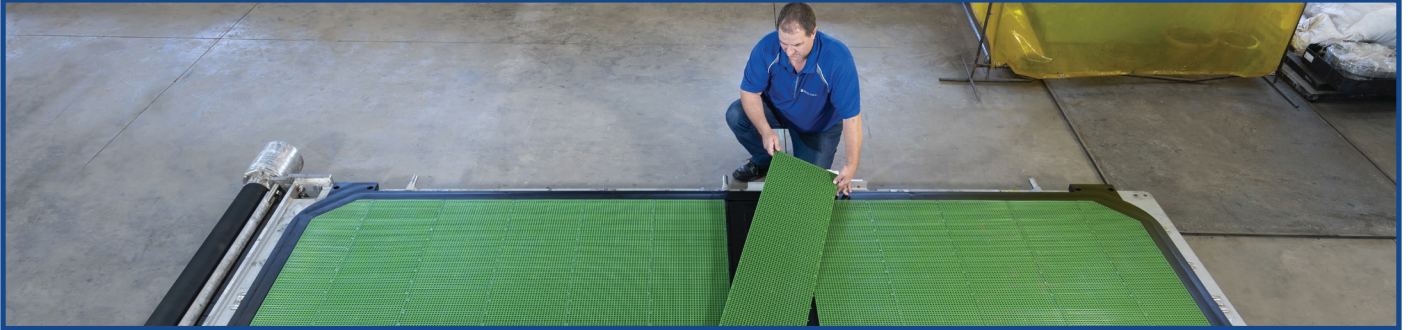



# ROYTEC

Global Separation Solutions

Johannesburg | Perth | Toronto | Yantai | Santiago

## Other ROYTEC equipment

- Vacuum Belt Filters & Vacuum Disc Filters
- Thickeners using RadFlow Feedwell Technology
- Dual Media Filters
- BGRIMM Flotation Cells, Magnetic Separators and Attritioning Mills
- Filter Presses
- Ceramic Disc Filters
- Ion Exchange Systems
- Flocculant / Coagulant Preparation Dosing Plants
- Linear Screens
- Dynamic Bed & Pinned Bed Clarifiers
- Vibrating Screens



### South Africa

- 3 Angus Crescent, Longmeadow Business Estate East Modderfontein, South Africa, 1609
- Tel: +27 (0) 11 608 0000
- Email: sales@roytecglobal.com

### Australia

- Ground Floor, 849 Wellington Str, West Perth, WA6005
- Tel: +61 (0) 427 732 243
- Email: sales.au@roytecglobal.com

### Canada

- Suite 703, 45 Sheppard Avenue East, Toronto, Ontario, Canada, M2N 5W9
- Tel: +1 647 477 0422
- Email: sales.ca@roytecglobal.com

### China

- Qingdao Roytec Equipment Technology Co. Ltd Suite 8049, No. 18 Baoding Road, Nanshan District Qingdao, Shandong Province, China, 266071
- Tel: +86 159 5359 6399
- Email: sales@roytecglobal.com

### Chile

- Santiago Office Suite 703, 45 Sheppard Avenue East, Toronto, Ontario, Canada, M2N 5W9
- Tel: +56 98 277 4227
- Email: sales.cl@roytecglobal.com